

PREPARATION OF HOLLOW YARN FILTRATION MEMBRANE MODULE

Publication number: JP61167407
Publication date: 1986-07-29
Inventor: UCHIDA YASUO; MIURA TAKASHI; MIYASAKA HISAYOSHI
Applicant: SUMITOMO BAKELITE CO
Classification:
- International: B01D63/02; B01D63/02; (IPC1-7): B01D13/01
- European:
Application number: JP19850006677 19850119
Priority number(s): JP19850006677 19850119

Report a data error here

Abstract of JP61167407

PURPOSE:To supply feed liquid for filtration to each hollow yarn evenly and to perform filtration with high efficiency by providing through holes to resin for sealing an end of a bundle of hollow yarns and bonding the hollow yarns to the resin with their another end held in open state. **CONSTITUTION:**A specified number of fine pores 10 are formed radially on the bottom surface 12 of a cylindrical vessel 9, and 'Teflon(R)' rods 11 are inserted into the fine holes 10. A bundle of hollow yarns 2 having an end aligned by cutting is inserted into the vessel 9 from the opening part of the vessel 9, and epoxy resin 3 is filled in the vessel 9 taking care not to cover the rods 11. After bonding and sealing the bundled hollow yarn 2 by hardening by crosslinking, the rods 11 are removed and through holes 5 are formed. Another end of the hollow yarn is held in the open state, and the hollow yarn is bonded with resin, etc.

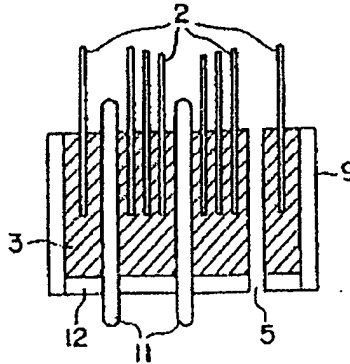

Data supplied from the esp@cenet database - Worldwide

⑨ 日本国特許庁(JP)

⑩ 特許出願公開

⑫ 公開特許公報(A) 昭61-167407

⑬ Int. Cl.⁴
B 01 D 13/01

識別記号 庁内整理番号
8014-4D

⑭ 公開 昭和61年(1986)7月29日

審査請求 未請求 発明の数 1 (全3頁)

⑮ 発明の名称 中空糸濾過膜モジュールの製造方法

⑯ 特 願 昭60-6677

⑰ 出 願 昭60(1985)1月19日

⑱ 発 明 者 内 田 安 雄 東京都千代田区内幸町1丁目2番2号 住友ベークライト株式会社内

⑲ 発 明 者 三 浦 孝 東京都千代田区内幸町1丁目2番2号 住友ベークライト株式会社内

⑲ 発 明 者 宮 坂 久 喜 東京都千代田区内幸町1丁目2番2号 住友ベークライト株式会社内

⑳ 出 願 人 住友ベークライト株式会社 東京都千代田区内幸町1丁目2番2号

明 細 書

1. 発 明 の 名 称

中空糸濾過膜モジュールの製造方法

2. 特 許 請 求 の 範 囲

容器の底面に細孔を設け、該細孔と同一断面形状を有し非接着性表面を有する棒材又は管材を該細孔に差し込み、所定本数の中空糸の一端を該容器の開口部より容器中に挿入し、架橋性樹脂を該棒材又は管材を覆わない程度に容器に充填し、該樹脂を架橋硬化し中空糸を結着封止した後該棒材又は管材を除去し貫通孔を設け、一方、他端の中空糸は中空糸が開口した状態で樹脂等により結着することよりなることを特徴とする中空糸濾過膜モジュールの製造方法。

3. 発 明 の 詳 細 な 説 明

中空糸濾過膜(以下中空糸という)は、膜充填密度が高く、濾過装置の小型軽量化を図ることができるため純水製造、食品加工その他の分野で多く用いられている。

通常濾過原液は中空糸の内部へ圧入され濾過液は外側へ取り出すことが多いが、極く濃縮な原液から微量の微粒子を除去する際には中空糸の外側から原液を圧

入し中空糸の内側へ濾過液を取り出すいわゆる外圧方式の方が効率的な濾過が行え有利である。

通常この様な方式により濾過を行う場合には、複数本の中空糸を束ね、その両端を樹脂などで結着封止した後、少なくともその一端を切断し中空糸の端部を開口せしめたモジュールを、円筒状の容器に中空糸の内部と外部が液密になる様に取り付け、該容器の側面から濾過液を中空糸の外部へ圧入し中空糸の内部に参出する濾過液を中空糸の開口端より取り出して濾過を行うものである。

かかる方法では濾過原液はその圧力により中空糸束を締めつけることとなり、その結果中空糸は束の中間では隣接中空糸と密着して濾過原液と接触できないため、束の外側の中空糸のみが濾過に参与することとなり、効率が低下するのが欠点であった。

この様な欠点を改良するため第1図に示す様な濾過器が考えられた。

第1図は本発明の濾過器の断面を模式的にあらわしたものである。中空糸束2の一端は樹脂3によって封止結着されているが、該樹脂には中空糸束2の中側に開口する貫通孔5が所定個数設けられている。中空糸

特開昭61-167407(2)

の他端は開口した状態で樹脂6によって結着されこの様に構成されたモジュールはハウジング4に中空系の内部と外部が液密になる様に取り付けられる。ハウジング4には原液圧入口1、濾過液流出口7および空気排出弁8が取り付けられる。

この様に構成された濾過器で濾過を行う際には原液は流入口1より貫通孔5を経て中空系2の中側へ供給される。従って中空系2は外側から締めつけられることなく、むしろ中側より上げられる形で濾過が行なわれるため隣接する中空系は互に密着することなく濾過原液と接触するため束を構成する中空系は無駄なくすべて濾過に寄与することとなり濾過の効率を飛躍的に向上させることが出来る。中空系の内部へ参出した濾過液は濾過液流出口7より取り出される。

貫通孔5は必要により空気などを導入して容器4の内部に気泡を生ぜしめ中空系を振動する際にも有用である。

かかる構造の濾過器において貫通孔5の配置を中空系2の中側に規則的に所定の配置に設けることが肝要であるが従来では極めて困難な作業であり多くの時間と労力を要するものであった。

ることができる。又第1図に示すハウジング4の一端に底面をとりつけて容器として用いても良い。又棒材は管材でもよく素材はテフロンに限らず非接着性表面を有するポリオレフィン類又は難型処理を施したその他の素材を用いることができる。

中空系束は一端を切り揃えた後第3図に示す様に容器中に均一に挿入した。既に棒材11により貫通孔5の位置が規定されているため中空系束2を均一に挿入することは極めて容易であった。挿入後容器開口部よりエポキシ樹脂を容器内に充填し、架橋硬化せしめ中空系束を結着封止した後、図面下方より棒材11を除去して貫通孔5を形成せしめた。この際孔が樹脂層を貫通するためにエポキシ樹脂を容器に充填する際樹脂が棒材11を覆わぬことが肝要である。

中空系束の他端は所定の長さに切り揃えた後通常の方法により中空系が開口した状態でエポキシ樹脂により径7.8mm、高さ約30mmの円筒状に成形し中空系を結着し、モジュールの全長を1060mmとした。

この様にして製造されたモジュールは内径80mm、外径88mmの塩化ビニル製ハウジングの内部に装着し両端部をエポキシ樹脂によりハウジングに液密になる

本発明者等は鋭意検討の結果、かかるモジュールの製造を容易にする本発明を完成するに至ったものである。

本発明は容器の底面の所定位置に所定個数の細孔を設け、該細孔と同一断面形状を有し、非接着性表面を有する棒材又は管材を細孔に差し込み所定本数の中空系の一端を該容器の開口部より容器中に挿入し架橋性樹脂を該棒材又は管材を覆わぬ様に容器に充填し該樹脂を架橋硬化し中空系を結着封止した後該棒材又は管材を除去し貫通孔を設け、一方、他端の中空系は開口した状態で樹脂等により結着することよりなることを特徴とする中空系濾過膜モジュールの製造方法である。以下実施例により本発明を詳細に説明する。

中空系として内径1.0mm、外径1.6mm、長さ1300mm、初期透水率 $1200l/m^2 \cdot hr \cdot atm$ のポリスルホン中空系800本を用いた。

容器として第2図に示すアクリル樹脂製内径74mm、外径78mm、高さ30mmの円筒状容器9の底面12に直径3mmの細孔10を放射状に9個設けテフロン製の直径3mmの棒材11を該細孔に差し込んだ。容器としては円筒状に限らず必要により箱状、その他形状とす

様に接着した。

この様に構成したハウジングの両端に原液圧入口、過液流出口および空気排出弁をとりつけ、第1図と類似の構成より成る濾過器を製造した。

かかる濾過器は貫通孔が所定の配置となっており中空系が均一に分布していることが認められた。このため濾過原液が各中空系に万遍なく供給され全ての中空系が濾過に寄与するため高効率に濾過を行うことが確かめられた。この結果は本発明による製造方法は非常に簡便でしかも高効率に濾過が行なえるため有用であると認められる。

4. 図面の簡単な説明

第1図は本発明による濾過器の断面を模式的に示した図面である。

図中 1、濾過原液流入口 2、中空系束 3、中空系結着封止する架橋性樹脂 4、ハウジング 5、貫通孔 6、中空系開口端部結着封止する架橋性樹脂 7、濾過原液流出口 8、空気排出

第2図は本発明実施例において用いたアクリル樹脂容器を模式的に示した図面であり、Aは側断面図、Bは底面を示す。

図中 9,アクリル製容器 10,細孔 11,細孔
10に差し込んだテフロン製丸棒 12,容器
底面

第3図はアクリル樹脂容器の細孔に丸棒を差し込み
中空系の一端を均一に容器内に挿入し、架橋性樹脂を
容器内に充填した状態および架橋硬化後丸棒を除去し
て貫通孔を形成する状態を模式的に示した図面である。

特許出願人 住友ベークライト株式会社

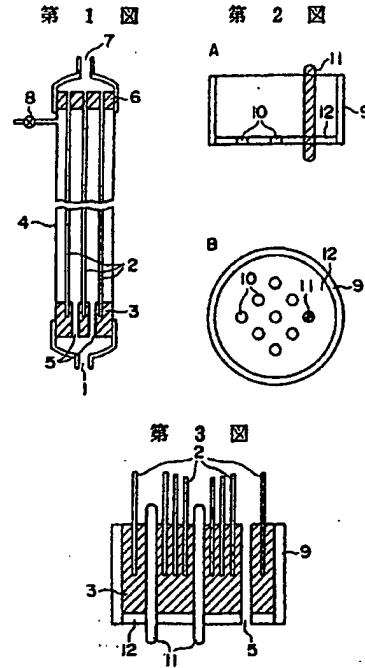

(19) JAPANESE PATENT OFFICE (JP)
(12) KOKAI PATENT JOURNAL (A)

(11) KOKAI PATENT APPLICATION NO.
SHO 61[1986]-167407

B 01 D 13/01

8014 - 4D

Examination Request: not filed No. of Invention: 1 (Total of 3 pages)

(54) Title of Invention Process for the Production of Hollow-Fiber Filtration Membrane Module

(21) Filing Number: Sho 60[1985]-6677

(22) Filing Date: January 19, Showa 60 (1985)

(72) Inventor: Yasuo Uchida, c/o Sumitomo Bakelite Co., Ltd., 1-2-2 Uchisaiwai-cho, Chiyoda-ku, Tokyo

(72) Inventor: Takashi Miura, c/o Sumitomo Bakelite Co., Ltd., 1-2-2 Uchisaiwai-cho, Chiyoda-ku, Tokyo

(72) Inventor: Hisayoshi Miyasaka, c/o Sumitomo Bakelite Co., Ltd., 1-2-2 Uchisaiwai-cho, Chiyoda-ku, Tokyo

(71) Applicant: Sumitomo Bakelite Co., Ltd., 1-2-2 Uchisaiwai-cho, Chiyoda-ku, Tokyo

Specification

1. Title of the Invention

Process for the Production of Hollow-Fiber Filtration Membrane Modulus

2. Patent Claim

A process for the production of a hollow-fiber filtration membrane modulus characterized by installing small holes at the bottom surface of a container; inserting rods or tubes, which have the same cross-sectional shape as that of the small holes and nonstick surface, into the holes; inserting a prescribed number of hollow fibers into the container from its opening; filling the container with a cross-linking resin not covering the rods or tubes completely; after bonding and sealing the hollow fibers by carrying out cross-linking and curing of the resin, removing the rods or tubes to form through holes; and meanwhile, bonding the other ends of the hollow fibers with a resin, etc., while holding the hollow fibers in their open state.

3. Detailed Explanation of the Invention

Hollow fiber filtration membranes (called hollow fibers, below) have high membrane-packing density enabling to make a small and light-weight filtration device, and consequently, they have been used widely in the fields of pure water manufacturing, food processing, etc.

In general, the stock solution for filtration is pressure-fed inside hollow fibers, and the filtrate is collected outside of the hollow fibers in many cases, but if only a trace amount of microparticles is to be removed from a relatively clear stock solution, the filtration method, so-called external pressure method feeding the stock solution from the outside of hollow fibers and collecting the filtrate inside them is advantageously used to carry out efficient filtration procedures.

When the filtration is carried out conventionally by using a system such as the one described above, a module, which is prepared by bundling a multiple number of hollow fibers and cutting open at least one of their ends after bonding and sealing both ends with a resin, is installed in a cylindrical container in a manner that both inside and outside of the hollow fibers are liquid-tight, the stock solution for filtration is pressure-fed from the side of the cylinder to the outside of the hollow fibers, and the filtrate seeping through into the inside of the hollow fibers is collected from their open ends.

In the process described above, the pressurized stock solution for filtration pressed the hollow fiber bundle. Those hollow fibers inside the bundle were liable to come into close contact with one another with adjoining hollow fibers, and consequently, they were prevented from coming into contact with the stock solution for filtration. Therefore, only those hollow fibers at the outer portion of the bundle were contributing to the filtration, and there was a shortcoming of poor filtration efficiency.

To eliminate this shortcoming, a filtration device as the one shown in Figure 1 has been proposed.

Figure 1 is a schematic drawing showing the cross section of the filtration device of this invention. One end of a hollow fiber bundle 2 is sealed and bonded with a resin 3, but this resin has a prescribed number of through holes 5 open to the inside of the hollow fiber bundle 2. The other ends of the hollow fibers are bonded in an open state to make a module, which is installed in a housing 4

so that both inside and outside of the hollow fibers are liquid-tight. The housing 4 is allowed to have an inlet 1 for the filtration stock solution to be pressure-fed, the outlet for the filtrate and air-discharging valve 8 is installed.

To carry out filtration procedures in a filtration device configured as described above, the stock solution for filtration is fed from the inlet 1 to the inside of the hollow fiber bundle 2 through the through holes 5. As a result, the filtration is carried out while the hollow fiber bundle 2 is not being tightened up from the outside but rather being expanded from the inside. Consequently, those adjoining hollow fibers are allowed to come into contact with the stock solution for filtration without coming into any close contact with one another. Therefore, all of the hollow fibers constituting the bundle are allowed to contribute in the filtration procedures without any waste, and the filtration efficiency can be drastically improved. The filtrate seeping through the inside of the hollow fibers is discharged from the filtrate outlet 7.

The through holes 5 are also useful for introducing air or other gas, and thus, generating air bubbles inside the container 4 to allow the hollow fibers to vibrate.

In a filtration device having the structure as described above, it is essential to have a prescribed regular configuration of the through holes 5 on the inside of the hollow fiber bundle 2. However, the process achieving it had extremely difficult procedures requiring a great deal of time and efforts.

As a result of studies carried out diligently, the inventors of this invention arrived successfully at this invention, therefore, it has become easy to produce a module such as the one described.

Specifically, this invention is a process for the production of a hollow-fiber filtration membrane modulus characterized by installing small holes at the bottom surface of a container; inserting rods or tubes, which have the same cross-sectional shape as that of the small holes and nonstick surface, into the holes; by inserting a prescribed number of hollow fibers into the container from its opening; by filling the container with a cross-linking resin to the extent not to cover the rods or tubes completely; after bonding and sealing the hollow fibers by carrying out cross-linking and

curing of the resin, removing the rods or tubes to form through holes; and meanwhile, bonding the other ends of the hollow fibers with a resin, etc., while holding the hollow fibers in their open state.

This invention is explained specifically in detail with an application example as follows.

The hollow fibers used were 800 strands of polysulfone hollow fiber having an inner diameter of 1.0 mm, outer diameter of 1.6 mm, length of 130 mm and initial water permeability of 1200 L/m²·h·atm.

The bottom surface 12 of an acrylic cylinder 9, having an inner diameter of 74 mm, an outer diameter of 78 mm and a height of 30 mm as shown in Figure 2, as a container was allowed to have 9 small holes 10 of 3 mm in diameter formed radially, and a Teflon rod 11 of 3 mm in diameter that was inserted into each small hole. The shape of the container is not necessarily limited to a cylinder, but if necessary, it is possible to use a box shape or other shape. It is also possible to use the housing 4 shown in Figure 1 as a container after installing a bottom on one end. The material for the rod or tube to be inserted to each of those small holes is not necessarily limited to Teflon, and it is possible to use other materials such as polyolefin resin with a nonstick surface, resin with a mold-releasing surface treatment, etc.

After aligning one end of the hollow fiber bundle by cutting, the hollow fibers are uniformly inserted into the container as shown in Figure 3. Because of the positions of the through holes 5 being specified by the rods 11, it was extremely easy to insert the hollow fiber bundle 2 uniformly. After feeding an epoxy resin from the opening of the container and carrying out cross-linking curing to bond and seal the hollow fiber bundle, the rods 11 were removed from the bottom to form through holes 5. In this case, it is essential for the epoxy resin not to cover the rods 11 completely when it is fed to the container so that the holes formed penetrate through the layer of the resin formed.

The other end of the hollow fiber bundle is cut to a required length, the conventional method was carried out to bond the hollow fibers in an open state by molding an epoxy resin in a cylindrical shape of 78 mm in diameter and about 30 mm long, and the total length of the module was set to 1060 mm.

The module prepared as described above was placed in a poly(vinyl chloride) housing of 80 mm inner diameter and 88 mm outer diameter, and the two ends were sealed liquid-tight to the housing.

The housing configured as described above was allowed to have an inlet for the filtration stock solution and filtrate outlet at the ends, an air-discharging valve was installed, and as a result, a filtration device having a configuration similar to that shown in Figure 1 was prepared.

The filtration device prepared was found to have those through holes in a required constant configuration, and the hollow fibers were found to be uniformly distributed. Therefore, the stock solution for filtration was uniformly fed to each of those hollow fibers allowing all of them to contribute to the filtration procedures. Consequently, it was confirmed that it is possible to carry out highly efficient filtration. Therefore, the process for the production of this invention is considered very simple and useful for highly efficient filtration.

4. Brief Explanation of Drawings

Figure 1 is a drawing schematically showing a cross section of the filtration device of this invention. In the figure, 1: filtration stock solution inlet, 2: hollow fiber bundle, 3: cross-linking resin bonding and sealing hollow fibers, 4: housing, 5: through hole, 6: cross-linking resin bonding and sealing open end of hollow fibers, 7: filtrate outlet and 8: air discharge valve.

Figure 2 is a drawing schematically showing an acrylic container used in the application example of this invention, A shows a side-view cross-sectional drawing, and B shows the bottom surface. In the figure, 9: acrylic resin container, 10: small hole, 11: Teflon round rod inserted into a small hole 10 and 12: container bottom surface.

Figure 3 is a drawing schematically showing the state of inserting round rods into small holes of an acrylic container and one end of hollow fibers uniformly, and filling the container with a cross-linking resin and the subsequent state of the rod being removed after curing of the cross-linking resin to form a through hole.

Patent Applicant: Sumitomo Bakelite Co., Ltd.

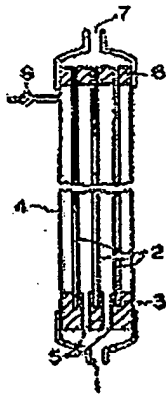

Figure 1

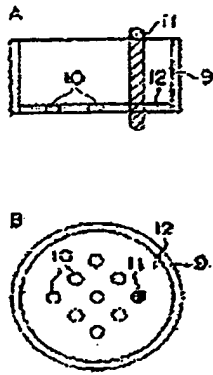

Figure 2

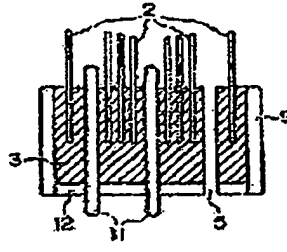

Figure 3